



# PWL12V100FT VRLA Battery

## Valve Regulated Lead Acid Battery

Our patented PWL Valve Regulated Lead Acid Battery is designed for telecom and CATV back-up applications.

### Specifications

- Front Access Design
- Grid Alloy: Lead Calcium Tin
- Case/Cover: PPE Resin (Flame Retardant, UL94 V-0, Halogen Free)
- Terminal: M6 threaded copper terminal

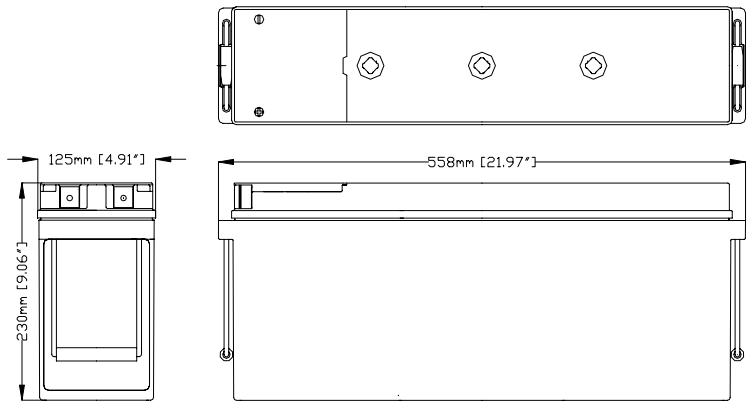

Model	Nominal Voltage (V)	Capacity 8HR (Ah)	Mass	Design Life @ 25 deg. C. (Year)	Dimensions			
					L	W	H	TH
PWL12V100FT	12	100	88lb 40kg	13	21.97" 558mm	4.91" 125mm	9.06" 230mm	8.42" 214mm

PWL12V100FT Amperes to Final Volts per Cell Temp.: 25 deg. C. ( 77F)											
		Discharge Time (hr)									
F.V.	20	12	10	9	8	7	6	5	4	3	2
1.75	5.42	8.85	10.4	11.5	12.5	13.9	15.5	18.0	21.4	26.8	36.2
1.80	5.25	8.44	10.1	11.1	12.4	13.6	15.4	17.6	20.9	26.0	35.6
1.85	4.87	8.16	9.75	10.6	11.7	12.9	14.6	16.9	20.1	24.9	33.8

Contact : **GS Battery U.S.A. Inc.** <http://www.gsbattery.com/>  
**US Headquarters**  
 1000 Mansell Exchange West, Suite 350  
 Alpharetta GA, 30022

Phone (678) 762-4818  
 Toll Free at (800) 472-2879  
 Fax: (678) 739-2132

# GS Battery (USA)