

# G3500 3.5A 6V&12V



Auto | Marine | RV | Powersport | Lawn & Garden

## UltraSafe® Battery Charger™



Charge Fully Drained Batteries Up To **120Ah**. Maintain All Battery Sizes.

ATVs, Lawn Mowers, Motorcycles, Cars, Trucks, Boats, RVs, Tractors, Equipment, And More.

Ultra-compact, rugged, and portable **UltraSafe®** Smart Charger. Features **spark proof technology** and **reverse polarity protection**. Charges **2X faster** than ordinary chargers. Stay connected 24/7 with **zero overcharge**.



### Start-Stop.

Counteracts increased cyclic energy demands placed on batteries in micro-hybrid vehicles.



### Firewall.

Multi-level safety barrier prevents unsafe and abnormal conditions.



### Optimization.

Stabilizes internal battery chemistry for increased performance and longevity.



### Load Tracking.

Dynamically changes charge current when a load is placed on the battery.



### Diagnostics.

Intuitive visual diagnostic tool for detecting reverse polarity, low-voltage or damaged batteries.



### Energy Save.

Minimizes energy consumption when full power is not needed.



### Thermal Monitor.

Internal temperature sensors adjust charge based on ambient climate.



### Safe.

Protects against reverse polarity, sparks, over-charging, overcurrent, open-circuits and overheating.



### Memory.

Returns to last-selected mode when restarted.



### Interactive.

Alters the charging process based on organic battery feedback.



### Recovery.

Applies a high-voltage pulse charge when low-voltage, sulfation, or lost capacity is detected.



### Rugged.

Dirt, water, UV, impact and crush resistant.



### CANBUS.

Automatically enables the charging port to charge CANBUS systems.



### Maintenance Plus.

Keeps the battery fully charged without over-charging, indefinitely.

Charge **6V&12V** Batteries Up To 120Ah. Maintain All Battery Sizes.

**NOCO**  
Since 1914

## Charging Modes

Mode	Explanation		
Standby	<b>No Power</b> In standby mode, the charger is not charging or providing any power to the battery. Energy Save is activated during this mode, drawing microscopic power from the electrical outlet. When selected, an orange LED will illuminate.	12V COLD/ AGM [Small]	<b>14.8V   900mA   Up To 35Ah Batteries</b> For charging 12-volt batteries in cold temperatures below 50°F (10°C) or AGM batteries. When selected, a blue LED will illuminate.
12V NORM	<b>14.5V   3.5A   Up To 120Ah Batteries</b> For charging 12-volt Wet Cell, Gel Cell, Enhanced Flooded, Maintenance-Free and Calcium batteries. When selected, a white LED will illuminate.	6V NORM Press & Hold	<b>7.25V   3.5A   Up To 120Ah Batteries</b> For charging 6-volt, Wet Cell, Gel Cell, Enhanced Flooded, Maintenance-Free and Calcium batteries. When selected, a white LED will illuminate.
12V COLD/ AGM	<b>14.8V   3.5A   Up To 120Ah Batteries</b> For charging 12-volt batteries in cold temperatures below 50°F (10°C) or AGM batteries. When selected, a blue LED will illuminate.	12V LITHIUM Press & Hold	<b>14.2V   3.5A   Up To 120Ah Batteries</b> For charging 12-volt lithium-ion batteries, including lithium iron phosphate. When selected, a blue LED will illuminate.
12V NORM [Small]	<b>14.5V   900mA   Up To 35Ah Batteries</b> For charging 12-volt, Wet Cell, Gel Cell, Enhanced Flooded, Maintenance-Free and Calcium batteries. When selected, a white LED will illuminate.	12V REPAIR Press & Hold	<b>16.5V   1.5A   Any Capacity</b> An advanced battery recovery mode for repairing and storing, old, idle, damaged, stratified or sulfated batteries. When selected, a red LED will illuminate and flash.

## Technical Specifications

Input Voltage AC:	110-120 VAC, 50-60Hz	Type of Batteries:	6V & 12V
Working Voltage AC:	85-130 VAC, 50-60Hz	Battery Chemistries:	Wet, Gel, MF, CA, EFB, AGM, LIB
Efficiency:	85% Approx.	Battery Capacity:	Up To 120Ah (12V), Up To 120Ah (6V), Maintains All Battery Sizes
Power:	60W Max	Housing Protection:	IP65
Low-Voltage Detection:	2V (12V), 2V (6V)	Cooling:	Natural Convection
Back Current Drain:	<5mA	Dimensions (LxWxH):	7.6 x 2.7 x 1.9 in (193 x 69 x 48mm)
Ambient Temperature:	0°C to +40°C, 32°F to +104°F	Weight:	1.13 Pounds (0.51 kg)
Charger Type:	8 Step, Smart Charger		

## Charging Steps

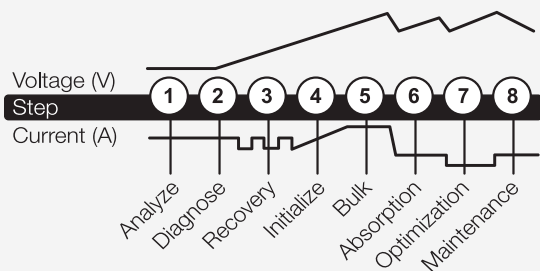

## What's In The Box

- G3500 Smart Charger
- Battery Clamp Connectors w/ Integrated Eyelets
- User Guide and Information Guide & Warranty

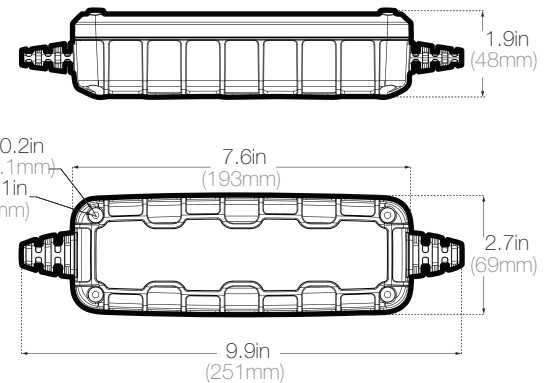

### Retail Packaging:

Dimensions: 10.47"x3.66"x4.80"

(266 x 93 x 122mm)

Weight: 1.86lbs (0.84kg)

UPC: 0-46221-10033-4

### Inner Carton:

Dimensions: 10.79"x4.02"x5.28"

(274 x 102 x 134mm)

(cont'd.) Weight: 2.11lbs (0.96kg)

### Master Carton:

Dimensions: 22.36"x12.91"x11.42"

(568 x 328 x 290mm)

Weight: 26.98lbs (12.24kg)

Quantity: 12

UCC: 10046221100331

Units Per Pallet: 360 Units



Intertek  
4001276

CONFORMS TO UL STD. UL1236  
CERTIFIED TO CSA STD. C22.2 No.107.2

AC Cable: 75 in (190.5cm)  
DC Cable: 56 in (142.24cm)

**NOCO**  
Since 1914