

# G1100 1.1A 6V&12V



Auto | Marine | RV | Powersport | Lawn & Garden

## UltraSafe® Battery Charger™



Charge Fully Drained Batteries Up To **40Ah**. **Maintain All Battery Sizes.** ATVs, Lawn Mowers, Motorcycles, Cars, Trucks, Boats, RVs, Tractors, Equipment, And More.

Ultra-compact, rugged, and portable **UltraSafe®** Smart Charger. Features **spark proof technology** and **reverse polarity protection**. Charges **2X faster** than ordinary chargers. Stay connected 24/7 with **zero overcharge**.

- |  |   |  |
|--|---|--|
|  <p><b>Start-Stop.</b><br/>Counteracts increased cyclic energy demands placed on batteries in micro-hybrid vehicles.</p>          |  <p><b>Energy Save.</b><br/>Minimizes energy consumption when full power is not needed.</p>                                    |  <p><b>Recovery.</b><br/>Applies a high-voltage pulse charge when low-voltage, sulfation, or lost capacity is detected.</p> |
|  <p><b>Firewall.</b><br/>Multi-level safety barrier prevents unsafe and abnormal conditions.</p>                                  |  <p><b>Thermal Monitor.</b><br/>Internal temperature sensors adjust charge based on ambient climate.</p>                       |  <p><b>Rugged.</b><br/>Dirt, water, UV, impact and crush resistant.</p>   |
|  <p><b>Optimization.</b><br/>Stabilizes internal battery chemistry for increased performance and longevity.</p>                   |  <p><b>Safe.</b><br/>Protects against reverse polarity, sparks, over-charging, overcurrent, open-circuits and overheating.</p> |  <p><b>CANBUS.</b><br/>Automatically enables the charging port to charge CANBUS systems.</p>                                |
|  <p><b>Load Tracking.</b><br/>Dynamically changes charge current when a load is placed on the battery.</p>                        |  <p><b>Memory.</b><br/>Returns to last-selected mode when restarted.</p>   |  <p><b>Maintenance Plus.</b><br/>Keeps the battery fully charged without over-charging, indefinitely.</p>                   |
|  <p><b>Diagnostics.</b><br/>Intuitive visual diagnostic tool for detecting reverse polarity, low-voltage or damaged batteries.</p> |  <p><b>Interactive.</b><br/>Alters the charging process based on organic battery feedback.</p>                                 |  |

Charge **6V&12V** Batteries Up To 40Ah. **Maintain All Battery Sizes.**

**NOCO**  
Since 1914

## Charging Modes

Mode	Explanation
Standby	<b>No Power</b> In standby mode, the charger is not charging or providing any power to the battery. Energy Save is activated during this mode, drawing microscopic power from the electrical outlet. When selected, an orange LED will illuminate.
12V NORM	<b>14.5V   1.1A   Up To 40Ah Batteries</b> For charging 12-volt Wet Cell, Gel Cell, Enhanced Flooded, Maintenance-Free and Calcium batteries. When selected, a white LED will illuminate.
12V COLD/AGM	<b>14.8V   1.1A   Up To 40Ah Batteries</b> For charging 12-volt batteries in cold temperatures below 50°F (10°C) or AGM batteries. When selected, a blue LED will illuminate.
6V NORM	<b>7.25V   1.1A   Up To 40Ah Batteries</b> For charging 6-volt, Wet Cell, Gel Cell, Enhanced Flooded, Maintenance-Free and Calcium batteries. When selected, a white LED will illuminate.
12V LITHIUM	<b>14.2V   1.1A   Up To 40Ah Batteries</b> For charging 12-volt lithium-ion batteries, including lithium iron phosphate. When selected, a blue LED will illuminate.

## Technical Specifications

Input Voltage AC:	110-120 VAC, 50-60Hz	Type of Batteries:	6V & 12V
Working Voltage AC:	85-130 VAC, 50-60Hz	Battery Chemistries:	Wet, Gel, MF, CA, EFB, AGM, LIB
Efficiency:	85% Approx.	Battery Capacity:	Up To 40Ah (12V), Up To 40Ah (6V), Maintains All Battery Sizes
Power:	30W Max	Housing Protection:	IP65
Low-Voltage Detection:	2V (12V), 2V (6V)	Cooling:	Natural Convection
Back Current Drain:	<5mA	Dimensions (LxWxH):	6.0 x 2.5 x 1.6 in (152 x 64 x 41mm)
Ambient Temperature:	0°C to +40°C, 32°F to +104°F	Weight:	0.81 Pounds (0.37 kg)
Charger Type:	8 Step, Smart Charger		

## Charging Steps

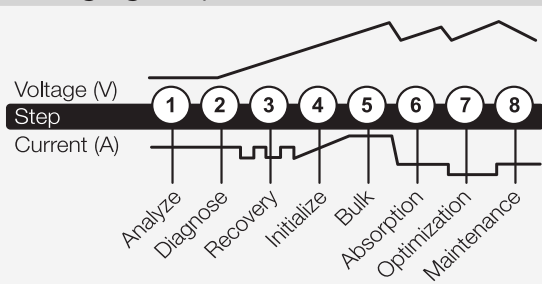

## What's In The Box

- G1100 Smart Charger
- Battery Clamp Connectors w/ Integrated Eyelets
- User Guide and Information Guide & Warranty

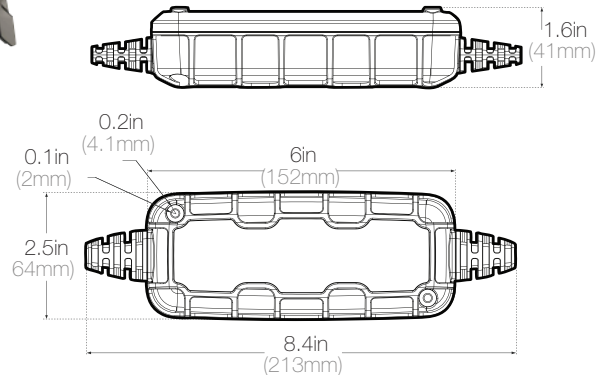

### Retail Packaging:

Dimensions: 9.02"x3.66"x4.41"  
(229 x 93 x 112mm)  
Weight: 1.50lbs (0.68kg)  
UPC: 0-46221-10032-7

### Inner Carton:

Dimensions: 9.33"x4.02"x4.88"  
(237 x 102 x 124mm)

(cont'd.) Weight: 1.74lbs (0.79kg)

### Master Carton:

Dimensions: 19.45"x17.09"x10.63"  
(494 x 434 x 270mm)  
Weight: 29.78lbs (13.51kg)  
Quantity: 16  
UCC: 10046221100324  
**Units Per Pallet: 384 Units**



CONFORMS TO UL STD. UL1236  
CERTIFIED TO CSA STD. C22.2 No.107.2

AC Cable: 75 in (190.5cm)  
DC Cable: 56 in (142.24cm)

**NOCO**  
Since 1914